

MITSUBISHI

TENSION CONTROLLER
MODEL LD-30FTA

INSTRUCTION MANUAL

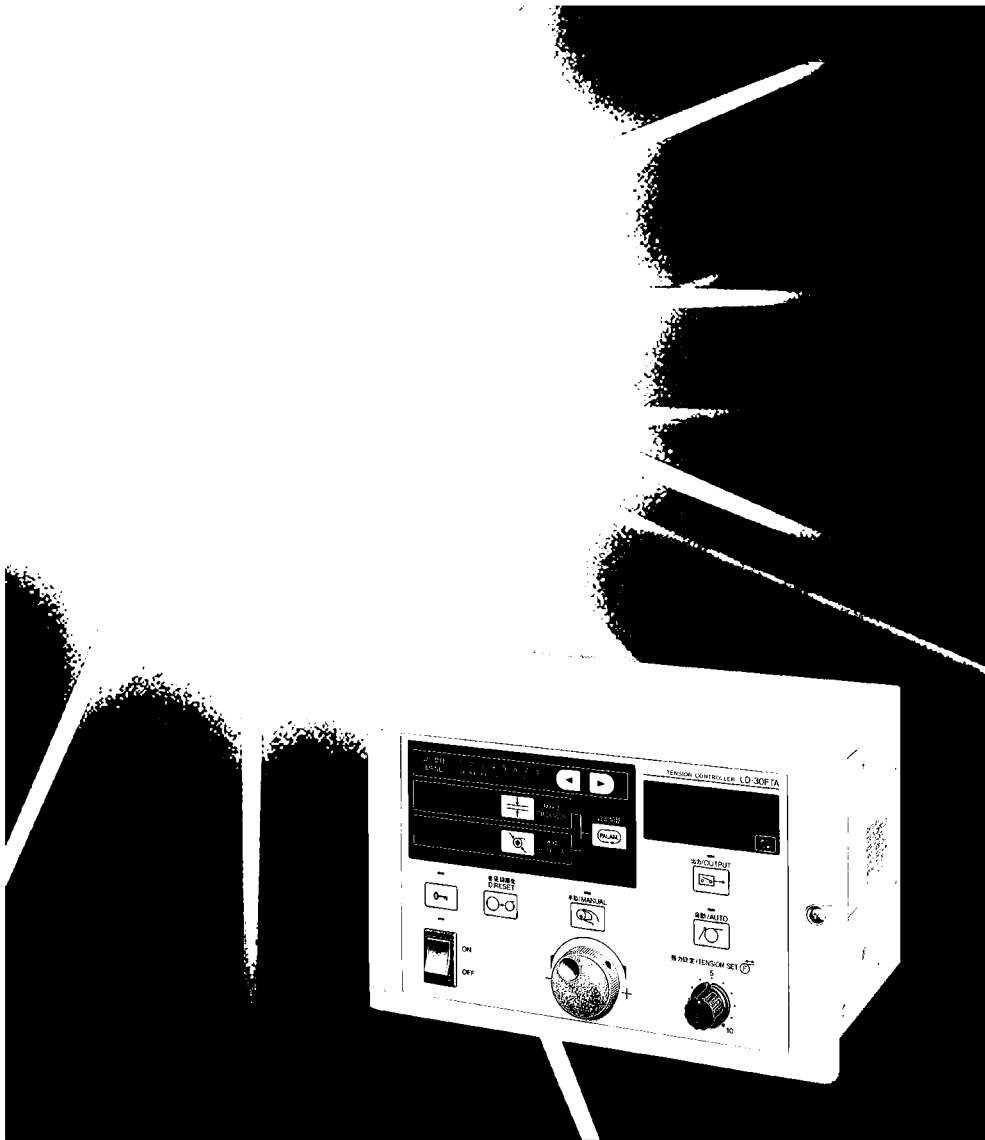



Cautions on Safety



(Make sure to read this page before using the unit.)



To assure safety
<ul style="list-style-type: none"> ● Make sure to read thoroughly this instruction manual before using the unit, and pay rigid attention to assure safety while using the unit. ● The unit is manufactured under the severe quality control. When a severe accident or loss is expected in the equipment used due to failure of the unit, provide the backup function or the fail-safe function in the system.



In this manual, cautions on safety are classified into "DANGER" and "CAUTION".



 Danger : When the unit is handled incorrectly, a dangerous situation may occur and the possibility of death or serious injury is expected.
 Caution : When the unit is handled incorrectly, a dangerous situation may occur and the possibility of medium or slight injury is expected or property damage exclusively is expected.



Even an item is classified as "CAUTION", its contents are important and it may lead to a serious result depending on the situation. Make sure to observe every item.



 Danger Turn off all the phases of the external power supply before starting installation and wiring.
 Otherwise, electrical shock or damage in the unit may occur. Make sure to turn off all the phases of the external power supply before starting installation and wiring.



 Danger Never open the covers while the power is supplied to the unit or the unit is operating.
 Never supply the power to the unit nor operate the unit while the main body cover and the terminal cover are open. When the covers are open, the high voltage area may be exposed and electrical shock may occur.



 Danger Never touch a switch with a wet hand.
 Otherwise, electrical shock may occur. Never touch a switch with a wet hand.

 Danger Assemble the emergency stop circuit outside the tension controller.
 Otherwise, the unit may become out of order and an accident may occur when malfunction occurs in the tension controller. Make sure to assemble the emergency stop circuit outside the tension controller.

 Danger Never use the unit in an atmosphere where inflammation or explosion can occur.
 Otherwise, inflammation or explosion may occur.

 Danger Perform the solid grounding or a better grounding.
 Otherwise, electrical shock may occur. Perform the solid grounding work or a better grounding work to the unit using a wire of 2 mm ² or more. However, never share the grounding with the strong electric system.

 Danger Design the installation plan using the wire size suitable to the current capacity.
 Use the wire size suitable to the current capacity to supply the power to the load. If a wire having smaller current capacity is used, the insulation sheath will be melted and insulation will become defective. In this situation, electrical shock and short-circuit may occur, and fire may occur.

 Danger Never modify nor disassemble the unit
 Never modify nor disassemble the unit. Otherwise, the unit may become defective or an accident such as fire, damage, etc. may occur.

 Caution Separate the wiring of the strong electric system from the wiring of the weak electric system.
Separate the wiring of the strong electric system from the wiring of the weak electric system, and make sure that noises are not superimposed on the wiring of the weak electric system. Otherwise, the unit may not operate correctly.

 Caution Confirm the ambient environments.
Never install the unit in a place where dusts, soot, conductive dusts or corrosive gas is present or a place exposed to high temperature, condensation or wind and rain. Otherwise, the unit may be damaged, malfunction or be deteriorated.

Caution

- We shall not be responsible for any damage caused by repair, disassembly, modification, etc. performed by a third party other than MITSUBISHI or a company specified by MITSUBISHI.
- The cautions on safety and the specifications described in the instruction manual are subject to change without notice.

Table of contents

SECTION 1 Outline	P2	<ul style="list-style-type: none"> ■ Functions and Features ■ Panel Configuration <ul style="list-style-type: none"> ○ DIP switch functions ○ Related to normal operation ○ Related to material thickness / initial diameter ○ Related to parameter setting ○ Menu selection operation
SECTION 2 General Specifications and Installation	P6	<ul style="list-style-type: none"> ■ Outside Dimensions and Environmental Specifications ■ Installation and Cautions ■ Internal Structure ■ Power Supply and General Description on Wiring Work
SECTION 3 I/O Specifications and Wiring	P10	<ul style="list-style-type: none"> ■ Terminal I / O ■ Description on I / O Operation
SECTION 4 Set Parameters	P12	<ul style="list-style-type: none"> ■ Set Items and Types ■ Selecting and item and changing the setting ■ Adjustment Procedure ■ Details of set item ■ When the reel diameter input is used
SECTION 5 Setting Inspection, Trial Run and Adjustment	P16	<ul style="list-style-type: none"> ■ Initial Inspection ■ Parameter Setting ■ Trial Run ■ Automatic Operation Confirmation ■ Abnormality Inspection ■ Maintenance / Inspection
SECTION 6 Setting Example	P18	<ul style="list-style-type: none"> ■ Application example : Proximity switch ■ Application example : Ultrasonic sensor
SECTION 7 Q&A on Operating Procedure	P20	<ul style="list-style-type: none"> ■ Manual torque adjustment and the role of the pulser dial ■ Relationship between the tension setting and the maximum tension ■ Role of the keyin inhibit key ■ How to use the menu selection function ■ Flickering of indicator lamps and its meaning ■ Taper ratio setting and output characteristics ■ Non-linearity compensation function ■ Guideline of allowable minimum tension ■ Major differences from the type LD-FB type tension control unit ■ Output remote input and the output ON/OFF key provided on the panel ■ Relationship between the acceleration/deceleration gain and the winding/unwinding/backward rotation input ■ Supplement related to attachment of the diameter analog input ■ Non-linear compensation number table

1 Outline

The type LD-30FTA tension control unit is an open loop type semi-automatic tension control unit adopting the reel diameter calculation control called "integrated thickness detection method".

In the integrated thickness detection method, the initial diameter and the material thickness are preliminarily set in the control unit, and the current reel diameter is calculated by subtracting (for unwinding) or adding (for winding) the material thickness multiplied by the number of rotations of the reel bobbin shaft from/to the initial diameter. (A proximity sensor is provided in the reel bobbin shaft so that the number of rotations can be detected.)

The calculation result is used to generate the voltage output of 0 to 24 V for a powder clutch/brake or hysteresis clutch/brake functioning as an actuator or generate the command voltage of 0 to 5 V for an amplifier for a servo motor.

The tension control is possible by an easy adjustment and the operation.

- Automatic control is possible only by the tension setting and setting a thickness of the material and an initial diameter.
- The input power supply is wide range of 100 to 240VAC.
- A material thickness and an initial diameter can be widely set.
- The reel diameter can be memorized even if the power supply is turned off.
- Many kinds of actuator which is the AC servo etc.

Advanced mode which supports various situations.

- Taper tension control.
- Inertia compensation function at accelerating and decelerating mode.
- Compensation function for non-linear torque of powder clutch/brake.
- Mechanical loss compensation function .

The ease of use was pursued.

- English/Japanese display and pictograph display
- Numeric setting by dial operation
- Advanced/easy mode switch
- Pleasant operativeness by eight kinds of material memories
The drive constant (thickness of the material, initial diameter, and taper rate, etc.) can be memorized up to eight kinds.
- Adoption of locking key to prohibit miss-operation prevention and display of invalid function.

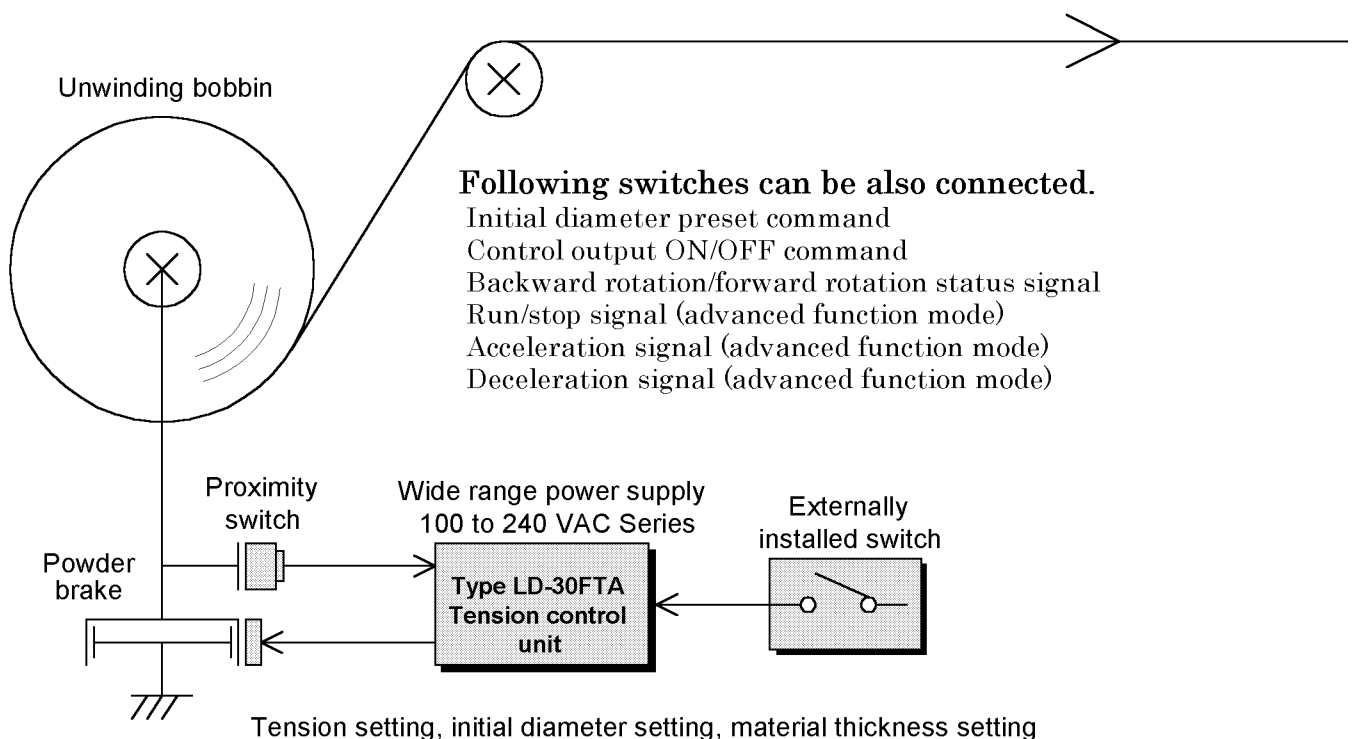

The ultrasonic sensor and the touch lever can be used.

The use of the ultrasonic sensor and the touch lever becomes possible by installing analog input board (LD-30FTA-1AD) of the option.

As a result, the operator becomes possible the automatic operative method only because of the tension setting according to an analog volume.

It is the best for such a control.

- Machine which does not need tension accuracy so much.
- Machine which moves slightly though the material is not heavy.
- Machine without place where tension detector is applied.
- Machine with serious manual adjustment of tension.
- Machine on which cost is not put so much.

Converting machinery

- Print machine and screen printing machine
- Slitting . cutting and laminating machine
- Paste putting machine and coating machine
- Washing machine and drying machine
- Cutting machine and punching machine
- Reel machine and inspection machine
- Wrapping machine and filling machine
- Surface processing machine
- Stranded wire machine
- Textile machine, needlework, and dye machine
- Rolling mill and wire drawing machine

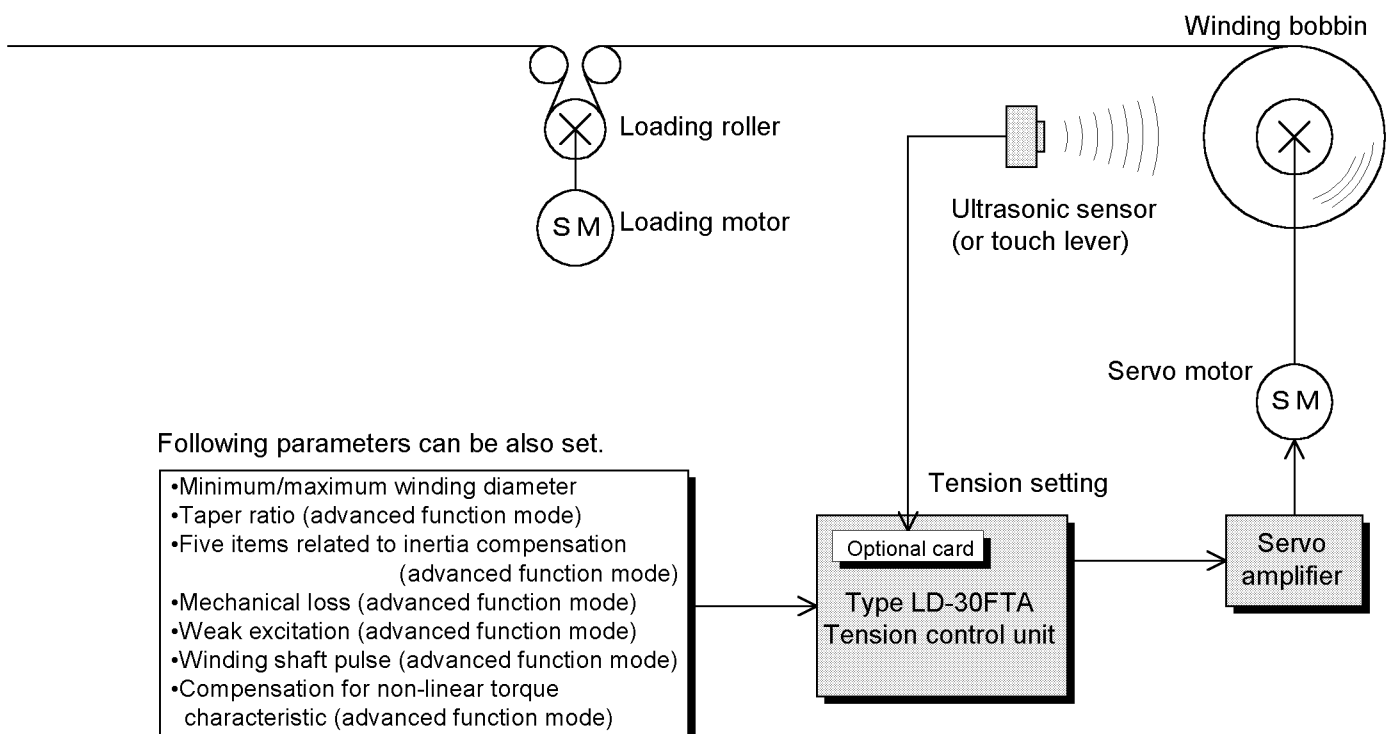

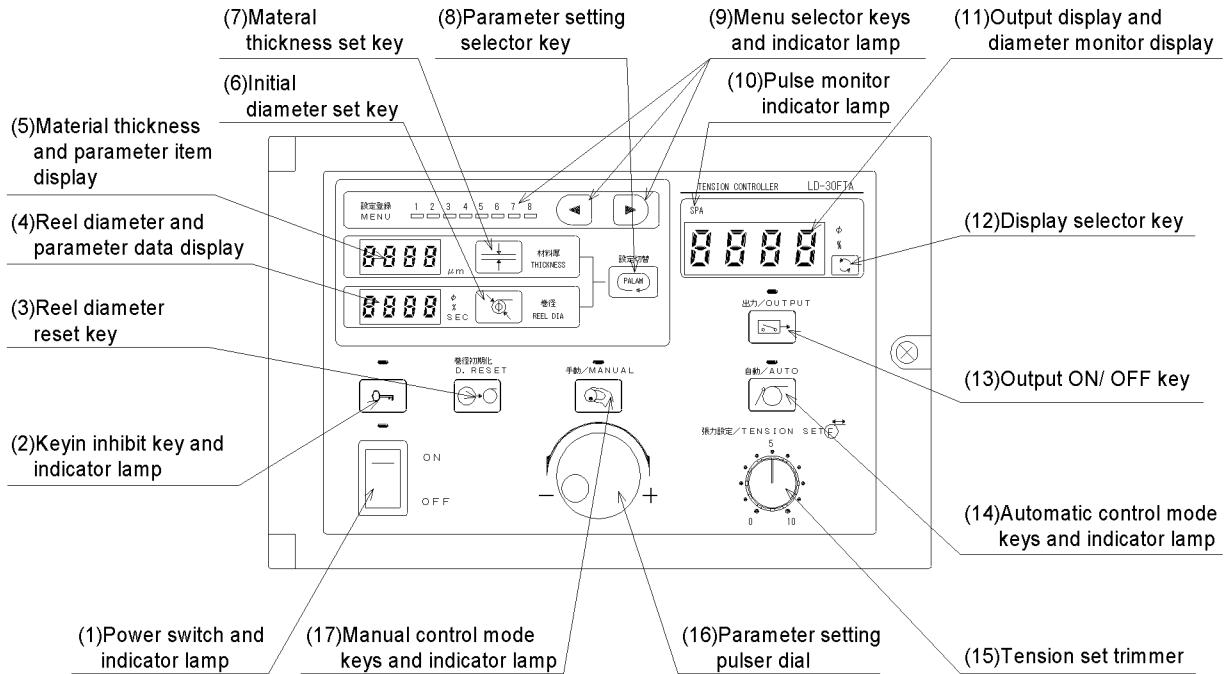

DIP switch functions

When the door on the panel is open, eight-bit DIP switch can be seen on the rear face of the door. When the power is turned off and turned on again, the setting status of the DIP switch is read.

- | | | | |
|---|-----------------------|---|---|
| 1 | Controlled shaft | : | Specifies unwindingl or windingl. |
| 2 | Thickness unit | : | Specifies 1 μ m or 0.1 μ m. |
| 3 | Diameter analog input | : | Specifies whether or not a mounted optional card is used. |
| 4 | Output remote | : | Specifies whether or not the output ON/OFF switch is connected externally. |
| 5 | No function | : | This switch is not defined yet. |
| 6 | Memory initialization | : | Returns diversified parameter data to the initial values selected when the tension control unit is shipped. |
| 7 | Function mode | : | Specifies the easy mode or the advanced function mode. |
| 8 | Operation mode | : | Specifies the operation mode or the tuning mode. |

1	2	3	4	5	6	7	8
Unwinding	× 1	Unused	Unused	Always	Normal	Easy	Operation
Controlled shaft	Thickness unit	diameter analog input	Output remote	No function	Memory initialization	Function mode	Operation mode
Winding	× 0.1	Used	Used		Initialization	Advanced function	Tunning

ON

Make sure to turn off the power at first, then change the setting.

OFF

All the bits of the DIP switch are set to ON when the tension contrc unit is shipped from the works.

Normal operation



Refer to p. 20

Switch manipulation

- When the power switch 1 is set to ON, the power indicator lamp is lit and the version of the tension control unit flickers on the monitor display 11 for approximately 2 seconds.
- Every time the output ON/OFF key 13 is pressed, the control output is toggled between ON and OFF. While the output is set to ON, the output indicator lamp is lit.
When the DIP switch is set so that the remote output can be used, the output can be also set to ON or OFF by that input.

(Note) Use the Output ON/OFF key 13 or [REM] input without using the Power switch 1 when the output is turned on and off.

- Allowable power switch cycles : 20,000 times

Manual control mode

- When the control mode key 17 is pressed, the manual mode is selected and the operation mode indicator lamp is lit.
In the manual mode, the control output of 0 to the maximum value is generated in accordance with the setting of the pulser dial 16, and the control output value is displayed as 0 to 100% on the manual output display 11.

Automatic control mode

- When the Automatic control mode key 14 is pressed, the automatic mode is selected and the operation mode indicator lamp is lit.
In the automatic mode, the tension can be set within the range of 0 to 100% by manipulating the tension set trimmer 15.
The 100% tension indicates the rated torque of the actuator converted for the reel shaft divided by a half of the maximum reel diameter (which is the maximum radius) set by the parameter.

Monitor display

- The contents displayed on the monitor display 11 can be changed over by manipulating the display selector key 12. The selected contents are indicated by the unit indicator lamp (reel diameter/output).
- The reel shaft pulse monitor indicator lamp 10 flickers by ON/OFF of the proximity switch.

Material thickness/initial diameter setting

When the reel diameter input is not used



Refer to p. 12~15

- When the material thickness set key 7 is pressed, the thickness currently set is displayed as a numeric on the material thickness display 5. (The decimal point position is determined by the parameter.)
- When the pulser dial 16 is turned clockwise or counterclockwise, a value displayed is increased or decreased so that the set value of thickness can be changed.
- When the initial diameter set key 6 is pressed, the initial diameter already set is displayed as a numeric on the reel diameter display 4.
- When the pulser dial 16 is turned clockwise or counterclockwise, a value displayed is increased or decreased so that the set value of initial diameter can be changed.
- When the material thickness set key 7 is pressed, the material thickness unit indicator lamp "μm" flickers. When the initial diameter set key 6 is pressed, the reel diameter unit indicator lamp "φ" flickers. When the corresponding set key 6 or 11 is pressed, the flickering symbol stops flickering and is lit.
- When the reel diameter reset key 3 is pressed and held for 1 sec or more, the current diameter being calculated is reset to the initial diameter set as described above.
- When the diameter analog input is used, the material thickness and the initial diameter are not required to be set. They are not displayed, and the key operations related to them are not accepted. → Refer to p. 15

When the reel diameter input is used

Parameter setting



Refer to p. 12~15

- When the parameter setting selector (PALAM) key 8 is pressed, the parameter item is displayed on the display in upper left 5 and the parameter data is displayed on the display in lower left 4. (Among the material thickness set key 7, the initial diameter set key 6, the parameter setting selector key 8 and the manual control key 17, the one pressed at last becomes valid, and the contents displayed on the displays 4, 5 are changed in accordance with the valid key.)
- Every time the parameter setting selector key 8 is pressed, the parameter items are read and displayed one by one in turn.
- The set value of the displayed parameter item can be increased or decreased by turning the pulser dial 16, and a new value becomes valid.
- When the keyin inhibit key 2 is pressed and held for 5 seconds or more, the keyin inhibit indicator lamp is lit. When the key 3 is pressed and held for 5 seconds or more again, the indicator lamp 4 is extinguished. By setting the keyin inhibit function, display of unused parameters can be prevented and change of the material thickness and the initial diameter by mistake during operation can be prohibited.
- By manipulating the menu selector keys 9, the menu selection indicator lamp can be changed over from 1 to 8.
- When diversified parameters are set to these menu numbers, the operator can select the operation constant in accordance with the material.

Menu selection



Refer to p. 20

The outside dimensions, the accessories and the general/environmental specifications of the type LD-30FTA tension control unit are as shown below.

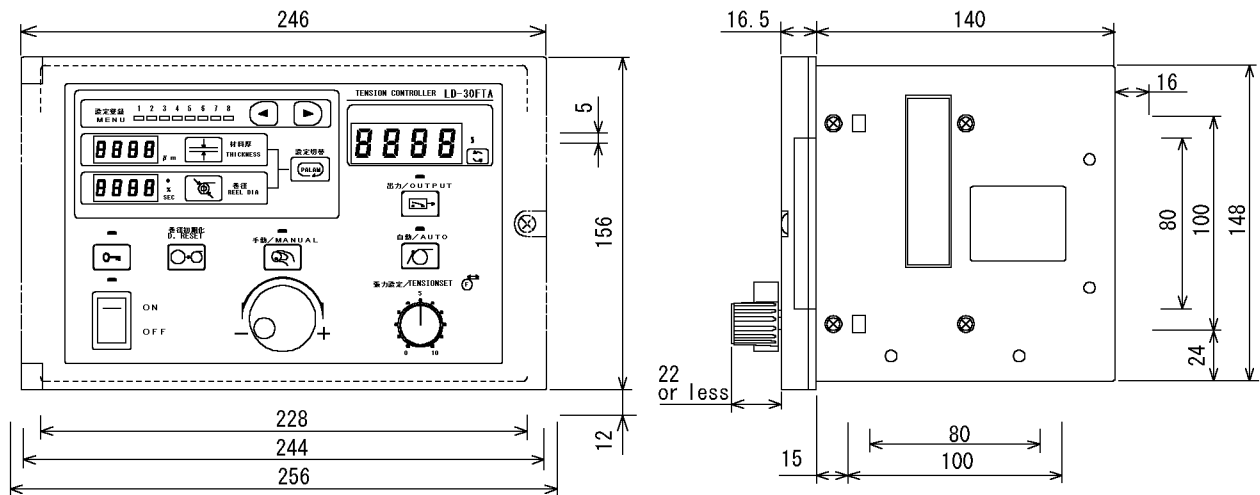

Weight : Approx. 3.5 kg
Outer painting color : Munsell 7.5Y 7.5 / 1

Accessories : Main body mounting plate : 1 pair
Main body-mounting leg fixing screw (M4 x 10): 4 screws



DANGER

Cautions on installation and environment

- Never use the tension control unit in an atmosphere in which fire taking or explosion may occur. If it is used in such an atmosphere, fire or explosion may be caused.
- Never drop cutting chips and electric wire chips when drilling screw holes and performing wiring works. If such chips are dropped inside, damage, fume, fire, malfunction, etc. may occur in the tension control unit.
- Never modify or disassemble the tension control unit. If it is modified or disassembled, failure may be caused or accidents such as fire and damage may occur.



CAUTION

Cautions on installation and environment

- Never install the tension control unit in a place with dusts, soot, conductive dusts or corrosive gas or place exposed to high temperature, condensation or wind and rain. Never install the tension control unit directly in a place to which vibrations or shocks may be applied. If the tension control unit is installed in such a place, damage, malfunction or deterioration may occur in it.
- When disposing of the tension control unit, treat it as industrial waste.

General/environmental specifications

Ambient temperature	: 0 to +40°C(during operation)
Ambient humidity	: 35 ~ 85%RH or less(Condensation shall not be allowed.)
Vibration resistance	: to 55 HZ, 0.5 mm(4.9 m/s ² max.), 2 hours in each of 3 axial directions (in conformance to JIS C0911)
Shock resistance	: 98 m/s ² , 3 times in each of 3 axial directions (in conformance to JIS C0912)
Power supply noise	: Using a noise simulator with noise voltage of 1,000 V _{p-p} , noise width of 1resistance μ s and frequency of 30 to 100 Hz
Withstand voltage	: 1,500 VAC for 1 min Measured between all terminals as a whole and ground terminal
Insulation resistance	: 5 M Ω or more when measured by a 500 VDC megger Measured between all terminals as a whole and ground terminal
Grounding	: 3 grounding(Common grounding together with strong electric system shall not be allowed.)
Working atmosphere	: Free from corrosive gas, flammable gas, conductive dusts and excessive dusts
Power switch cycles	: Less than 20,000 times

This tension control unit can be installed on the floor, wall or panel surface.

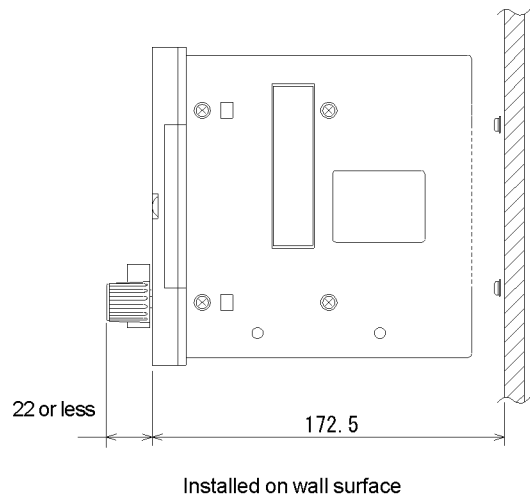
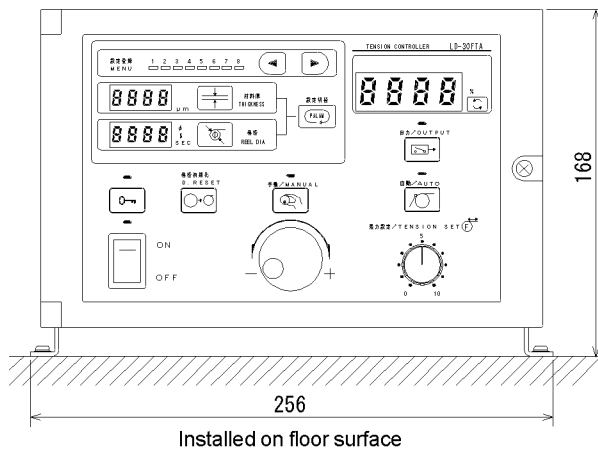

Screw hole dimensions when installed on floor or wall

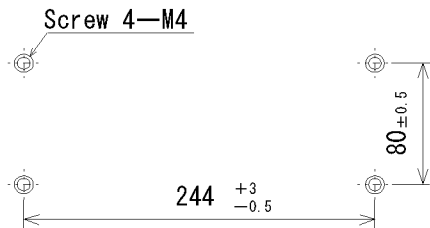

Panel cut dimensions when installed on panel

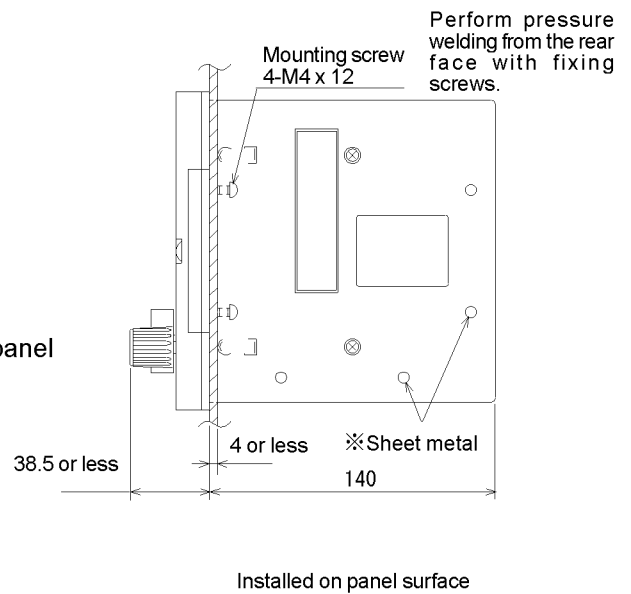
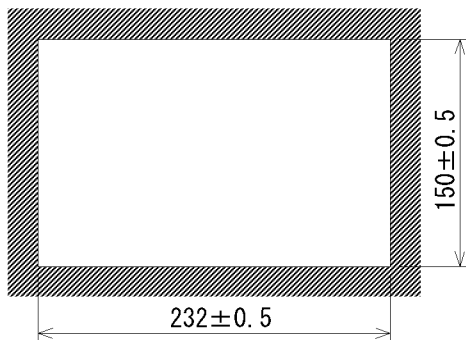

Perform Class 3 grounding in either position marked with ※ in which the main body mounting plate is not fixed.

CAUTION Use mounting screws offered as accessories.

When installing the tension control unit on the floor surface or wall surface, use the screws offered as accessories to fix the main body and the mounting legs.

Screws whose length is not less than 10 mm cannot be used because such screws may be in contact inside the main body.

CAUTION Perform grounding of sheet metal.

Perform Class 3 grounding for the casing on sheet metal using a screw hole on the side on which the main body mounting plate is not fixed.

When the front door is open, the terminal block for external connection can be seen inside the box. Pull out the cables to the outside from the cable outlet slots provided in the lower portion of the box.

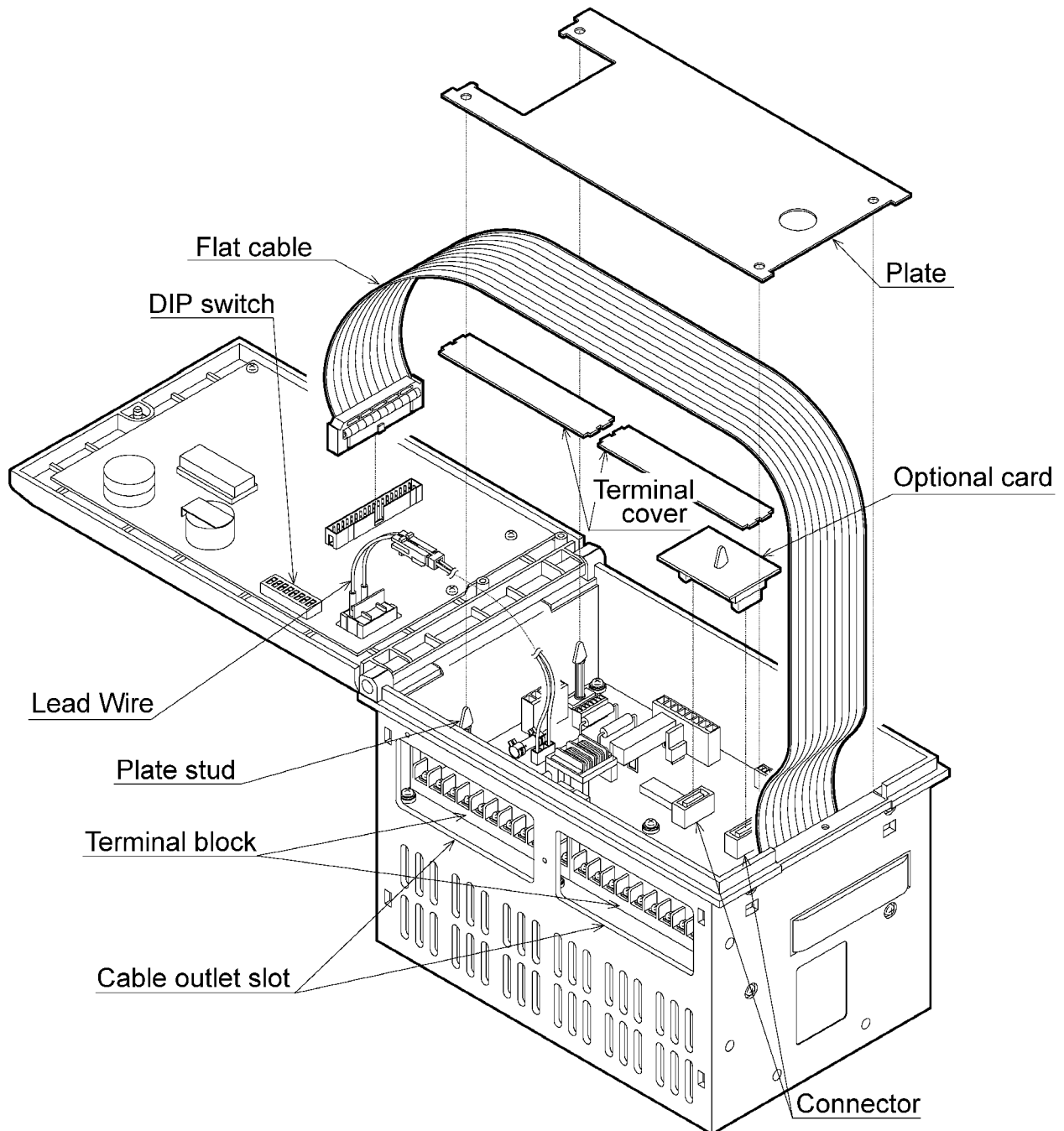

Mounting the type LD-30FTA-1AD optional card

(When you used the option function)

Make sure to shut down all the phases of the external power supply. Then, open the front door. Disconnect the flat cable. Remove the plate inside the box (by holding the tip of the studs at the four corners and pulling out the plate). Insert an optional card into the connector. Attach the plate again.

The power circuit configuration of the tension control unit is as shown in the figure below. Connect the power supply of 100 to 240 VAC (-15 to +10%), 50/60 Hz between the power terminals L and N. When the maximum control output of 24 VDC, 3 A is generated, the power consumption is approximately 300 VA.

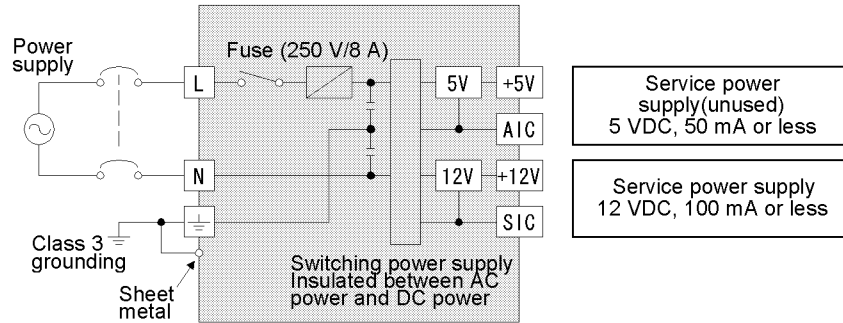

The terminal symbols and their layout in the terminal blocks are as shown in the figure below.

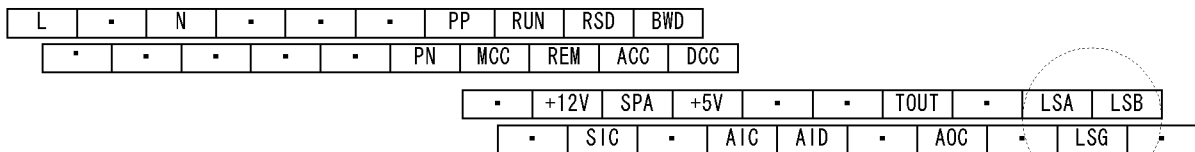

Don't use LSA ~ LSG

! DANGER Cautions on connection of power supply/ground and used cables

- Make sure to shut down all the phases of the external power supply. Then, start the installation/wiring work.
- If all the phases are not shut down, you may get electric shock or the tension control unit may be damaged. Perform Class 3 grounding to the ground terminal and the sheet metal of the casing of the tension control unit with electric wires of 2 mm² or more. If Class 3 grounding is not performed, electric shock may be caused.
- When supplying the power to a load, use an electric wire in accordance with the current capacity. If the electric wire is thinner than necessity, the insulating sheath may be melt and imperfect insulation may be caused. As the result, electric shock, short-circuit or fire may occur.

! CAUTION Cautions on prohibition of use of unused terminals and separation of wiring system

- Connect the AC power supply correctly to specified terminals. Never use unused terminals for the outside. If the AC power supply is not correctly connected or unused terminals are used, the tension control unit may be damaged.
- Separate the strong electric system from the weak electric system. Never perform common grounding for them. If common grounding is performed, noise may be superimposed on the weak electric system wiring and malfunction may be caused.
- Please do not leave the line in the controller case so much for the malfunction prevention when wiring is too long and the line is generated too much.
- Please do not bring the AC power supply cable close to the panel side for the malfunction prevention.

Note

This product is an electronic equipment in which a micro computer (CPU) is built in. If the CPU has become out of order caused by insertion of conductive foreign objects or abnormal noise into the main body, the output of this product is fixed. When disorder of the CPU is caused by noise, the product can be recovered to the normal status by turning off the power and turning it on again.

General description on wiring work

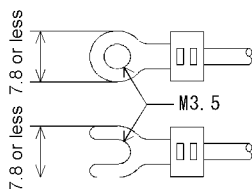

- Use crimp-style terminals whose dimensions are as shown in the figure on the left.
- The terminal tightening torque shall be 0.5 to 0.8 N · m. Tighten the terminals securely so that malfunction will not be caused.
- Perform Class 3 grounding to the analog I/O cables and the winding shaft pulse input cable with shielded cables on the signal receive side.
- Never let the I/O cables pass through a duct together with other power cables. Never bind the I/O cables together with other power cables.
- Generally, the allowable wiring length shall be 10 m or less to assure safety against noise.

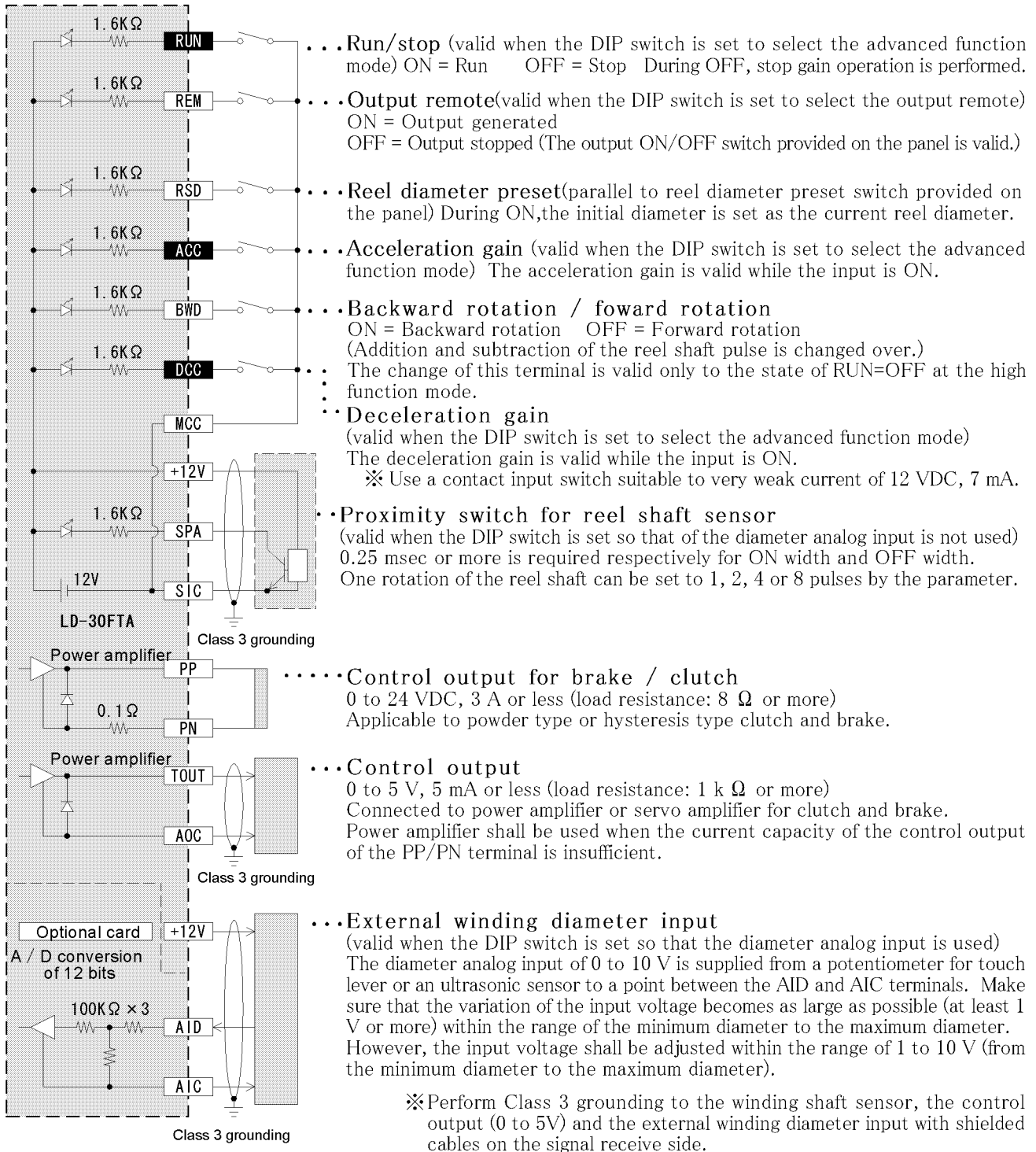

Recommended sensors

- Proximity switch : Manufactured by SUNX
Type GX-N12M proximity switch
Type GX-N18M proximity switch
- Potentiometer for touch lever : Manufactured by MIDORI SOKKI
Type CPP-45 potentiometer (2 k Ω type)
Free rotation type with effective angle of 300 degrees
(Left and right stoppers are not provided.)
- Ultrasonic sensor : Type UNAM30U9103 (maximum detection distance: 100 - 600 mm)

Example of unwinding control

When the DIP switch is set to select the advanced function mode

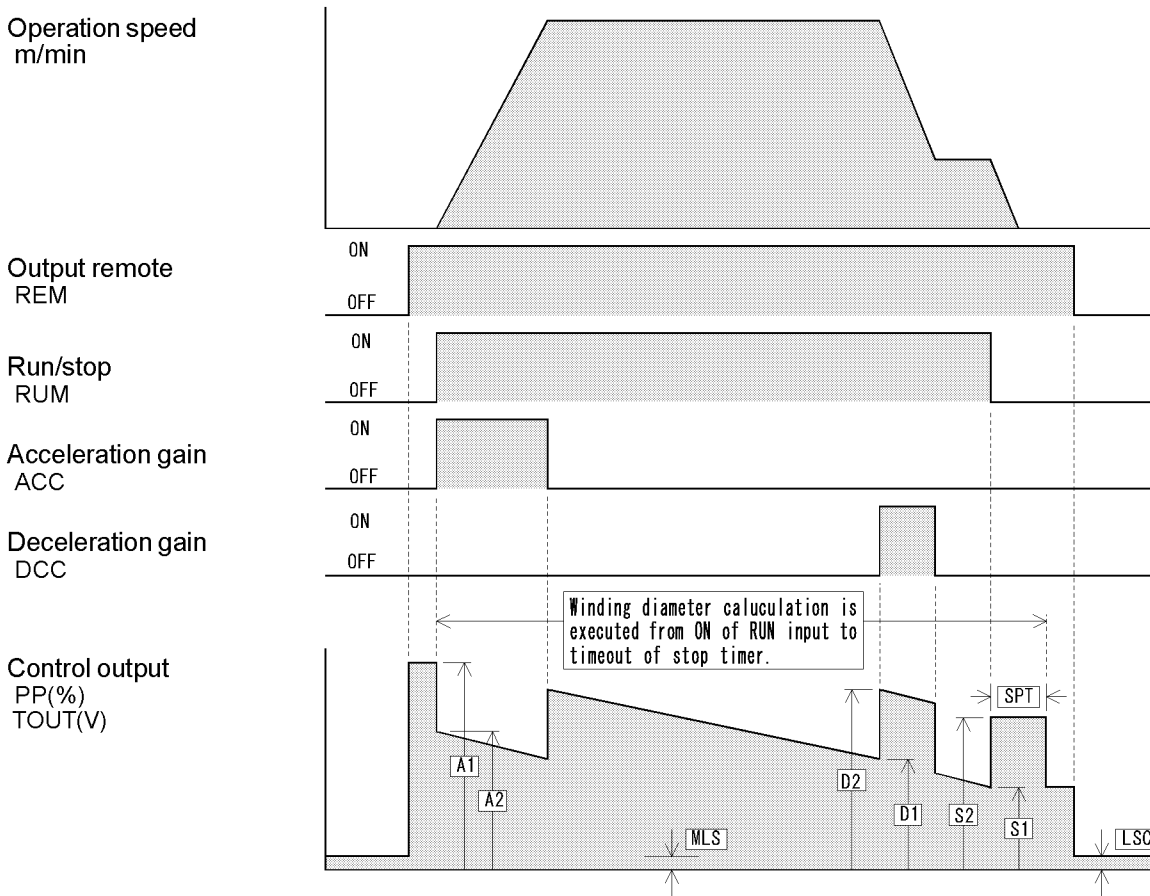

Parameters

For the setting procedure, refer to p. 12 to p. 15.

- A2/A1 = Acceleration gain
Can be set within the range of 0.05 to 4.0, but is limited by 100% output.
- D2/D1 = Deceleration gain
Can be set within the range of 0.05 to 4.0, but is limited by 100% output.
- $S2 = S1 \times SPG + SPB$
Limited to 100% output or less.
- SPG = Stop gain
Can be set within the range of 0.05 to 4.0.
- SPB = Stop bias
Can be set within the range of 0 to 50% of the maximum control output.
- SPT = Stop timer
Can be set within the range of 0 to 100 sec.
- LSC = Little excitation
Can be set within the range of 0 to 50% of the maximum control output.
- MLS = Mechanical loss
Used in unwinding, and can be set within the range of 0 to 50% of the maximum control output. This set value is always added to the control output.

- When the output remote input is set to ON, the control output is generated. When the output remote input is set to OFF, the weak excitation output set by the parameter is generated.
- When the RUN input is set to ON in interlocking with start of operation of the machine, winding diameter calculation is started.
When the acceleration gain input at the time of start of the machine is set to ON, the control output in accordance with the acceleration gain set by the parameter is generated. (In unwinding, the setting should be performed so that the output is decreased.)
- As to deceleration of the machine, when the deceleration gain input is set to ON, the control output in accordance with the deceleration gain set by the parameter is generated. (In unwinding, the setting should be performed so that the output is decreased.)
- As to stop of the machine, when the RUN input is set to OFF, the control output in accordance with the stop gain and the stop bias set by the parameters is generated. When the stop timer reaches timeout, the control output is returned to a value which was valid immediately before the RUN input was set to OFF.
- The winding diameter is calculated after the RUN input is set to ON until the stop timer reaches timeout. When the DIP switch is set so that the diameter analog input is used, the winding diameter is not calculated but the control output in accordance with the signal voltage supplied to the external winding diameter input terminal is generated. (Controls of other items including the acceleration gain, the deceleration gain and the stop gain are performed in the same way as described above.)

4 Set Parameters

Set Items and Types

Set item list

Set item	Set range		Initial value	Unit	Setting management		Item No	Function mode
	Minimum value	Maximum value			Menu	System		
Tension setting	0	100	—	%	—	—	—	Easy/advanced function
Material thickness setting	1/0.1	9,999/999.9	50	μm	○	×	—	Easy/advanced function
Initial diameter setting	1	2,000	500	mm	○	×	—	Easy/advanced function
Taper ratio setting	0	100	100	%	○	×	1	Advanced function
Stop timer setting	0.0	100.0	0.0	s	○	×	2	Advanced function
Stop gain setting	5	400	100	%	○	×	3	Advanced function
Stop bias setting	0	50	0	%	○	×	4	Advanced function
Deceleration gain setting	5	400	100	%	○	×	5	Advanced function
Acceleration gain setting	5	400	100	%	○	×	6	Advanced function
Mechanical loss setting	0	50	0	%	×	○	7	Advanced function
Little excitation setting	0	50	0	%	×	○	8	Advanced function
Winding shaft pulse quantity setting	1,2,4,8		1	—	×	○	9	Advanced function
※1 Non-linearity compensation	0	200	0	—	×	○	A	Advanced function
Minimum diameter setting	1	Maximum diameter	100	mm	×	○	F	Easy/advanced function
※2 Maximum diameter setting	Minimum diameter	2,000	500	mm	×	○	0	Easy/advanced function

Note

- An item for which the setting management "menu" column is set to "○" is a parameter handled as a setting registration menu.
 - An item for which the setting management "menu" column is set to "×" is not handled as a menu but can be set in the adjustment mode exclusively. And the setting value cannot be altered when the [RUN] input terminal is turned ON in advanced mode.
 - Parameters whose item No. is 1 to 9 are valid exclusively while the DIP switch is set to select the advanced function mode.
 - Parameters whose item No. is not (B) or (C) are read by the PALAM key. Parameters whose item No. is (B) or (C) are read by the material thickness set/winding diameter set key.
- ※1 • When the non-linearity compensation is not used, be sure to set to zero.
- ※2 • When diameter analog input is no use, Maximum diameter setting Minimum value is 1mm φ .

Set value types

Set value	Batch change by menu changeover	Display/non-display in operation mode	Mode in which setting can be changed
Material thickness/initial diameter setting	Enabled	Adjustment/operation mode	Adjustment/operation mode
Menu setting	Enabled	Items 1 to 6 are set by lock key.	Adjustment/operation mode
System setting	Disabled	Always undisplayed in operation mode.	Setting is enabled in adjustment mode only.

Note

- When the keyin inhibit function is set to each of the items 1 to 6 of menu setting in the tuning mode, the corresponding items are not displayed in the operation mode. Accordingly, the set value of such items cannot be changed in the operation mode.
 - In the initial status of the tuning mode, the keyin inhibit function is set. Upon necessity, press and hold the keyin inhibit key provided on the panel for 5 sec or more to extinguish the keyin inhibit indicator lamp. Each of the items 7 to 9, F and 0 of system setting is displayed in the tuning mode exclusively. They cannot be set in the operation mode.
 - The setting of the material thickness and the initial diameter can be changed in both the tuning mode and the operation mode.
 - For the system setting items, the setting value cannot be altered when the [RUN] input terminal is turned ON in advanced mode.
 - As to the material thickness, the initial diameter and an item to which the keyin inhibit function is not set in the tuning mode, when the keyin inhibit function is set in the operation mode, change of the setting with the pulser dial are disabled.
- However, the manual output adjustment is valid without regard to the keyin inhibit function setting status. Menu selection is disabled while the RUN input terminal is set to ON in the advanced function mode. In the easy mode, when the keyin inhibit is put in the operation mode, the setting of the thickness of the material and the initial diameter with the pulser dial and the change of menu can not change.

Selecting an item and changing the setting

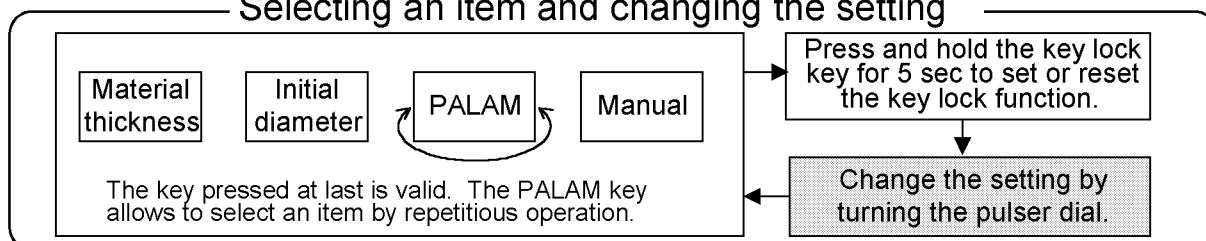

Adjustment Procedure

Set the DIP switch to select the adjustment mode. Select the simple or advanced function mode. Select use or non-use of the winding diameter input. Then, set the power to ON.

The setting of the DIP switch is read when the power is set from OFF to ON. For approximately 2 sec after the power is set to ON, the version of the tension control unit is displayed on the display in upper right of the panel.

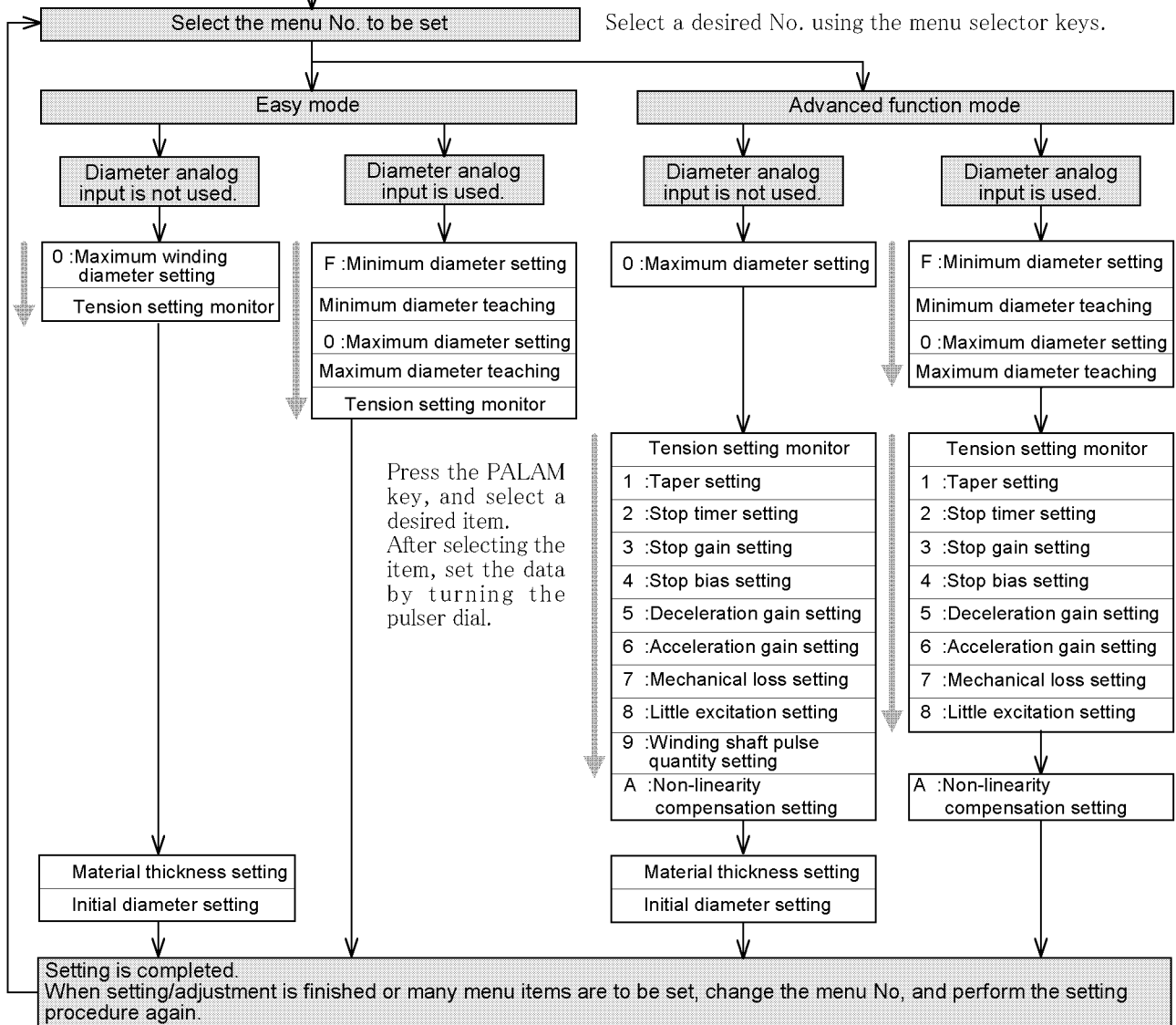

Items to which the key lock function is set in the adjustment mode are not displayed and their setting cannot be changed in the operation mode. When the key lock function is set in the operation mode, change of the setting of a displayed item and menu selection are prohibited in the simple mode.

Set the power to OFF. Set the DIP switch to select the operation mode. Set the power to ON.

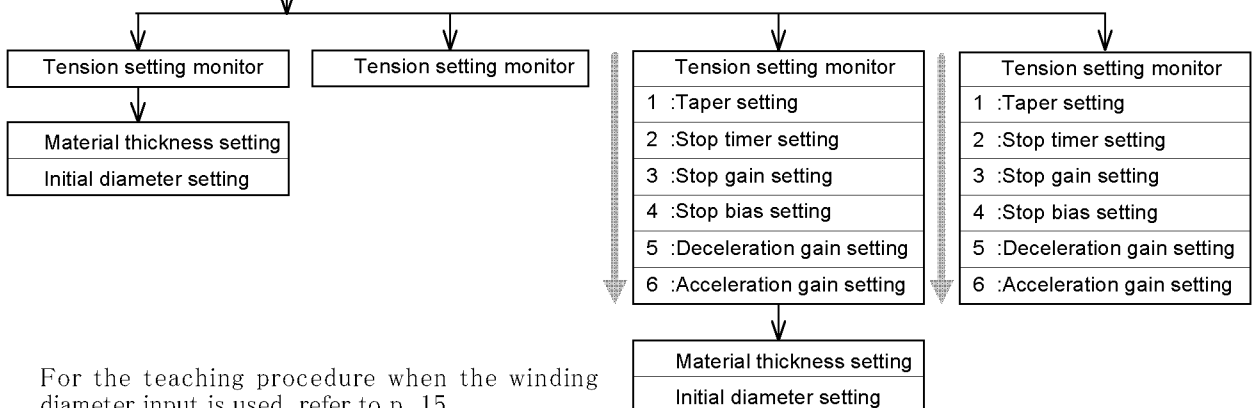

For the teaching procedure when the winding diameter input is used, refer to p. 15.

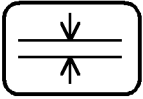

When the reel diameter input is used, refer to p. 15.

• Material thickness setting

When the material thickness key is pressed, its set value is displayed.

The unit of the material thickness setting is changed over between 1 μ m and 0.1 μ m in accordance with the setting of the DIP switch. The decimal point is displayed on the 7-segment display for the material thickness setting. When the material thickness setting is changed while the reel diameter is being calculated, the reel diameter calculation is changed in proportion to the material thickness.

By this function, in the material thickness setting, the calculated reel diameter and the actual reel diameter can be aligned with each other. When many materials are wound in one layer as in a wire material, the setting shall be in accordance with the following formula.

$$\text{Material thickness set value} = (\text{Thickness of one layer} / \text{Number of turns of one layer})$$

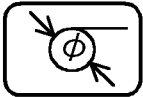

• Initial diameter setting

When the winding diameter key is pressed, its set value is displayed.

After the material has been changed, after the reel diameter reset key is pressed and held for 1 sec or more or while the [RSD] terminal input remains ON, the initial diameter setting is valid. The initial diameter setting is regarded as the diameter at start of the reel diameter calculation (preset value for winding diameter calculation).



Every time the PALAM key is pressed, the items are displayed one by one in turn as shown below.

Display symbols are represented in simplified alphabets as shown below.

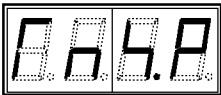

• Tension setting monitor . . . TNS.P (TeNsion Set. Present)

Monitors the tension set value, and displays the percentage set by the tension set trimmer. This item is displayed before the taper setting.

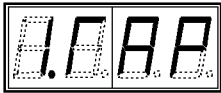

1 Taper setting . . . TAP (TAPer)

Calculates the taper ratio in the advanced function mode while regarding the setting 100% as the constant tension operation.

The taper control is same both in unwinding and winding. Reverse taper calculation for unwinding is not performed. Same control pattern is used both in the unwinding control mode and the winding control mode.

$$\text{Taper ratio} = 100 - (100 - \text{taper set value } \%) \times (\text{Current winding diameter} / \text{Maximum winding diameter})$$

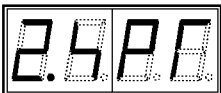

2 Stop timer setting . . . SPT (StoP Timer)

Sets the inertia compensation timer for stop in the advanced function mode.

After the RUN contact input is set from ON to OFF, the stop gain and the stop bias are valid for the control output for the period set here.

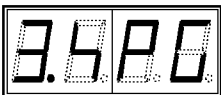

3 Stop gain setting . . . SPG (StoP Gain)

Sets the inertia compensation which determines the control output magnification ratio while the stop timer is available in the advanced function mode.

The gain can be set within the range of 5 to 400% so that a same value can be used both in unwinding and winding.

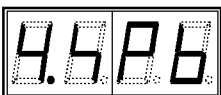

4 Stop bias setting . . . SPB (StoP Bias)

Determines the bias for the control output while the stop timer is available in the advanced function mode.

Set the stop bias when the tension of the material is fluctuated caused by the mechanical inertia while the reel diameter is small and the control output is also small.

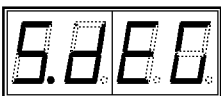

5 Deceleration gain setting . . . DEG (DEceleration Gain)

Sets the inertia compensation which determines the gain for the control output while the DCC contact input is ON in the advanced function mode. The set range is 5 to 400%.

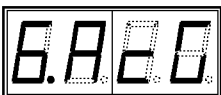

6 Acceleration gain setting . . . ACG (ACceleration Gain)

Sets the inertia compensation which determines the gain for the control output while the ACC contact input is ON in the advanced function mode. The set range is 5 to 400%.

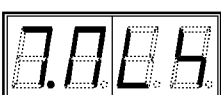

7 Mechanical loss setting . . . MLS (Mechanical LoSs)

Sets the mechanical loss bias for the control output used in winding control. The set range is 0 to 50%.



8 Little excitation current setting . . . LSC (Low Supply Current)
 Is valid in the advanced function mode exclusively and set so that the output does not become 0 and the little excitation current is applied in a powder clutch/brake even if the control output is set to OFF by the ON/OFF switch or the output remote.
 Adjust the little excitation current so that the reel shaft is rotated even when the material is removed.

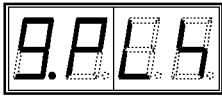

9 Reel shaft pulse quantity setting . . . PLS (reel shaft PuLSe)
 Is set so that the reel shaft pulse per rotation of the reel shaft increases and the control output is not drastically changed by input of the reel shaft pulse while the material is thick in the advanced function mode.
 Set a larger value as the material is thicker.

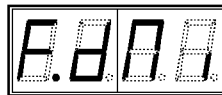

F Minimum diameter setting . . . DMI (Diameter MInimum)
 Displays the minimum diameter teaching data when the reel diameter is entered from the external analog input.
 This item is displayed exclusively when the analog input is selected by the DIP switch.
 When a value is set to this item, the analog voltage is entered and the teaching operation is performed, the minimum reel diameter is automatically recognized.
 Though the relationship between the voltage and the reel diameter is reverse each other between the touch arm and the ultrasonic sensor, the internal diameter calculation is automatically changed based on evaluation of the maximum diameter teaching voltage.

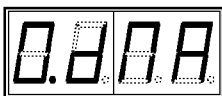

0 Maximum diameter setting . . . DMA (Diameter MAXimum)
 Sets the maximum diameter of the machine.
 All tension control calculations are performed based on a value set here.
 When the tension set trimmer is set to the maximum value and the taper ratio is set to 100%, the control output is regarded as 100% (24 V).

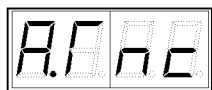

A Non-linearity compensation setting . . . TNC (Torque Non-linear Compensation)
 The non-linear torque characteristics for the impressed voltage of powder clutch and brake as well as hysteresis clutch and brake is corrected.
 The compensation numbers for the powder clutch and brake as well as hysteresis clutch and brake, which are used in accordance with the table shown in Page 24, are set.
 When the non-linearity compensation is not used, be sure to set to zero.

When the diameter analog input is used

1. Turn off the power. Set the DIP switch to select the tuning mode. Turn on the power.
2. When the PALAM key is pressed, the minimum diameter is displayed on the display in upper left on the panel.
3. By turning the pulser dial, adjust the value on the display in lower left so that it becomes the minimum diameter.
4. Place the touch lever in the minimum diameter position. Or face the reel bobbin of the minimum diameter against the ultrasonic sensor.
5. Press and hold the reel diameter reset key on the panel.
6. When the PALAM key is pressed again, the maximum diameter is displayed on the display in upper left on the panel.
7. By turning the pulser dial, adjust the value on the display in lower left so that it becomes the maximum diameter.
8. Place the touch lever in the maximum diameter position. Or face the reel bobbin of the maximum diameter against the ultrasonic sensor.
9. Press and hold the reel diameter reset key on the panel .

Now, teaching is completed.

The figure on the left shows an example of characteristics between the input voltage and the reel diameter in which the diameter analog input voltage is 7.0 V at the minimum diameter 100 and the diameter analog input voltage is 2.0 V at the maximum diameter 500.

The tension control unit saves the characteristics entered by teaching, calculates the reel diameter in accordance with the actual input voltage, and generates the control output in accordance with the calculated reel diameter.

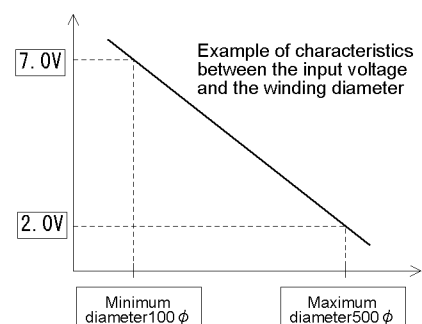

1 Confirming the selection

- Before starting operation, make sure that a tension control unit, an actuator and sensors are correctly selected. The output current of the type LD-30FTA tension control unit is 24 VDC, 3 A or less. If clutches/brakes to be used exceed this output current, use power amplifiers together.
- The capacity of an actuator is selected based on the production line speed multiplied by the operation tension. A tension beyond this capacity can be set in a tension control unit. In such a case, however, the actuator may be burned out.

Make sure that the operator understands the available upper limit tension determined based on the heat capacity of the actuator.

- If the tension is too Low, operation becomes unstable when the machine is started up or stopped. Determine an appropriate lower limit, and let the operator understand it.

2 Operation sequence

- Check the operation sequence and the emergency stop sequence.

Especially, when a servo motor is used as an actuator, the motor may become out of order if the material is cut. When the material is cut, set the speed limit input for the motor to 0.

3 Checking the wiring

- Erroneous connection of the power terminal (confusion of phases also in a motor), contact of the DC I/O cables and the power cable, short-circuit in the output cable may cause serious damages.

Before turning on the power, make sure that the power supply is correctly connected, that grounding is correctly performed and that the I/O cables are correctly wired.

- Never perform the megger test (measurement of insulation resistance).

4 Setting the inside of the tension control unit

- Set the seven-bit DIP switch provided on the rear face of the panel. Set the operation mode to the tuning mode.

Parameter Setting

Tension control unit power=ON

Set the parameters using the procedures described in p. 12 to p. 15.

Even if the easy mode is selected, make sure to set the maximum reel diameter when the diameter analog input is not used.

When the diameter analog input is used, set the maximum diameter, set the minimum diameter and perform teaching.

Trial Run

All power=ON

Set the tension control unit to the manual mode. Give an appropriate output. Make sure that mechanical operations are normal including the rotation direction of a motor. Especially, when a servo motor is used, make sure preliminarily that the parameters of the servo amplifier are set appropriately.

(Set the servo loop type to the torque mode, and specify the regenerative option. Make sure that the rated torque is achieved when a 5 V command is given.)

Automatic Operation Confirmation

All power=ON

Automatic Operation Confirmation All power = ON

Turn off the power of the tension control unit. Set the DIP switch to select the operation mode. Turn on the power. Perform automatic operation using the procedure described in p. 5 .

When the diameter analog input is not used, change the setting of the material thickness and the initial diameter using the procedure described in p. 5 .

To prevent miss operation during operation, use the keyin inhibit key.

Make sure to select a menu while the machine is stopped. (In the advanced function mode, changeover of the menu is disabled while the RUN terminal input is ON.)

Abnormality Inspection

Check abnormality of the tension control unit during trial run and adjustment or during actual operation in accordance with the table shown below.

Item	Phenomenon	Countermeasures
Short-circuit of load related to power supply	The power indicator lamp is not lit even if the power switch is set to ON.	<ol style="list-style-type: none"> 1 Check whether the supply voltage between the L and N terminals is 100 to 240 VAC (-15 to +10%), 50/60 Hz. If this voltage is not given, correct the wiring. 2 A fuse may be melted down caused by insertion of foreign objects or abnormal load. Even if a melted fuse is replaced, the tension control unit may not be recovered to the normal status.
	The control output is not generated even if the pulser dial is turned in the manual mode.	<ol style="list-style-type: none"> 1 When control output is not generated even if the output ON/OFF key provided on the panel is manipulated, check whether the clutch/brake model is appropriate (The rated current should be 3 A or less.), whether the clutch/brake is correctly connected and whether short circuit has not occurred. 2 When short-circuit has occurred in the load, remove the cause, turn off the power for several minutes, and turn on the power again. Then, the tension control unit will be recovered to the normal status. 3 When the TOUT/AOC terminal is used, make sure that the load resistance is 1 kΩ or more.
Abnormal operation in automatic mode	Sufficient control output is not generated in the automatic mode.	If the maximum reel diameter parameter is not set appropriately, sufficient output cannot be obtained.
	Appropriate control output is not generated in accordance with change in the winding diameter.	<ol style="list-style-type: none"> 1 When the diameter analog input is not used Observe the reel shaft pulse monitor, and check whether the reel shaft pulse is entered. If the pulse is not generated, check whether an appropriate proximity switch is used, whether the proximity switch is correctly wired and whether the ON duration and the OFF duration are appropriate. Make sure that the voltage of the reel shaft pulse between the input terminals SPA and SIC is 1 V or less while the input is set to ON and 9 V or more while the input is set to OFF. 2 When the winding diameter input is used Check whether the minimum diameter and the maximum diameter are set appropriately and whether teaching has been performed. Check whether change in the voltage between the input terminals AID and AIC is appropriate against change from the minimum diameter to the maximum diameter. Inside the tension control unit, an analog value of 0 to 10 V is handled as a digital value of 0 to 4095 steps. For example, when the variation of the input voltage against change from the minimum diameter to the maximum diameter is 1 V, the resolution becomes 409 steps.

Maintenance/Inspection

Consumable parts which may reduce the service life are not built in the type LD-30FTA tension control unit. However, check the following items as periodical inspection.

- Make sure that the temperature inside the panel is not abnormally high caused by a heating body or direct sunlight.
- Make sure that powder dusts and conductive dusts are not present inside the panel.
- Make sure that abnormality in the wiring, loose terminals and other abnormalities are not detected.



DANGER Cautions on emergency stop

Provide the emergency stop circuit for the machine outside the tension control unit. If it is built in the tension control unit, the machine may become out of order and accidents may be caused when malfunction occurs in the tension control unit.



CAUTION Cautions on operation

- Never manipulate switches and keys with wet hand. If you touch them with wet hand, you may get electric shock.
- Never supply the power to or operate the tension control unit while the main body door, the terminal cover, etc. are open. If the high voltage portion is exposed, you may get electric shock.

6 Setting Examples

Application example : Proximity switch

This is an example of intermittent feeding with which feeding of the material is paused and punching is performed. Though it is intermittent feeding, the winding motor is continuously rotating and the clutch is continuously slipping and applying tension.

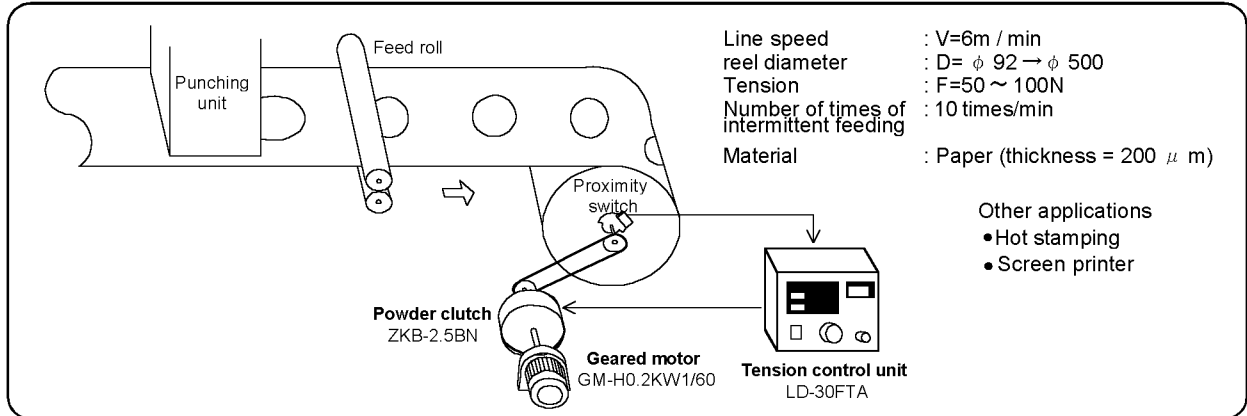

Use example of a proximity switch (simple mode)

When the winding diameter is changed from 92 to 500 and the material thickness remains 200 μm in the example above

Setting of the DIP switch (This step is required only at the time of initial startup, and is not required during normal operation.)

	1	2	3	4	5	6	7	8
ON	Unwinding	× 1	Unused	Unused	Always	Normal	Easy	Operation
DIP switch	Controlled shaft	Thickness unit	Winding diameter input	Output remote	No function	Memory initialization	Function mode	Operation mode
OFF	Winding	× 0.1	Used	Used		Initialization	Advanced function	Tuning

(Initial value setting)

	1	2	3	4	5	6	7	8
ON	Unwinding	× 1	Unused	Unused	Always	Normal	Easy	Operation
DIP switch	Controlled shaft	Thickness unit	Winding diameter input	Output remote	No function	Memory initialization	Function mode	Operation mode
OFF	Winding	× 0.1	Used	Used		Initialization	Advanced function	Tuning

※ Set the eighth (operation mode) DIP switches to "RUN" when you drive.

Maximum diameter setting

(This step is required only at the time of initial startup, and is not required during normal operation.)

- Select the maximum reel diameter using the initial diameter set key, and enter φ 500 by turning the pulser dial.
- Change the operation mode of the DIP switch to "run", and turn on the power again.

Setting procedure (This step is required only when the material is changed.)

- Press the material thickness set key, and set the material thickness to 200 μm by turning the pulser dial.
- Press the initial diameter set key, and set the reel diameter to φ 92 by turning the pulser dial.
- Press the reel diameter reset key.

● Maximum diameter display



● Winding diameter display



● Material thickness display

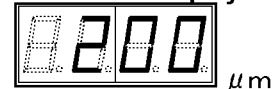

● Winding diameter display



Trial run (This step is required only at the initial startup, and is not required during easy operation.)

- Press the manual control mode key, and set the output ON/OFF switch to ON.
- Check diversified functions such as the motor and the sequence.

Automatic operation

- Press the automatic control mode key (only when the manual mode is selected).
- Adjust the tension to an appropriate value by turning the tension set trimmer.

Application example : Ultrasonic sensor

Electric wire not processed by the sheathing unit yet is unwound while such a tension as not to slack the electric wire is applied.

Because the open loop control is performed, hunting does not occur in the traverse direction.

Because an ultrasonic sensor detects the reel diameter, the initial diameter and the wire diameter are not required to be set.

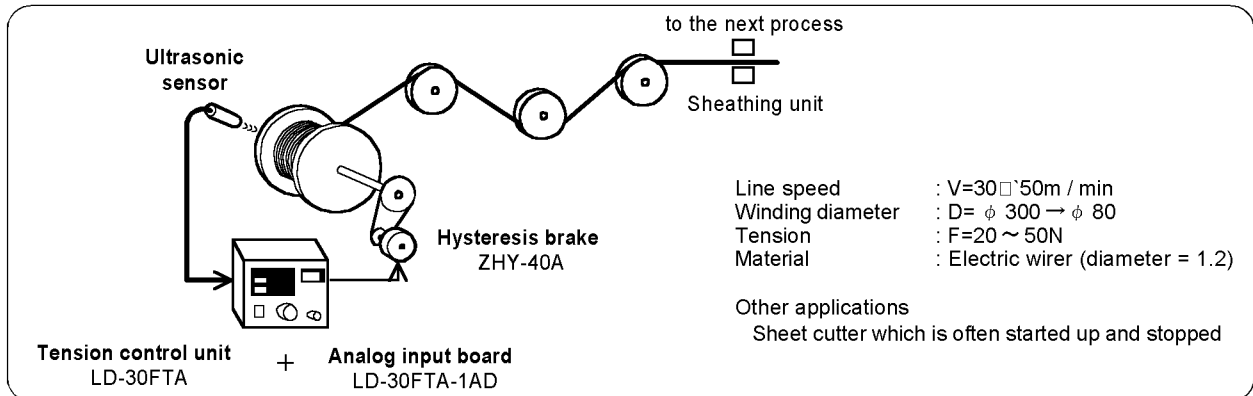

Use example of an ultrasonic sensor (simple mode) (equivalent for a touch lever)
 When the reel diameter is changed from 300 to 80 in the example above

Setting of the DIP switch (This step is required only at the time of initial startup, and is not required during normal operation.)

	1	2	3	4	5	6	7	8
ON	Unwinding	$\times 1$	Unused	Unused	Always	Normal	Easy	Operation
DIP switch	Controlled shaft	Thickness unit	Winding diameter input	Output remote	No function	Memory initialization	Function mode	Operation mode
OFF	Winding	$\times 0.1$	Used	Used		Initialization	Advanced function	Tuning

(Initial value setting)

	1	2	3	4	5	6	7	8
ON	Unwinding	$\times 1$	Unused	Unused	Always	Normal	Easy	Operation
DIP switch	Controlled shaft	Thickness unit	Winding diameter input	Output remote	No function	Memory initialization	Function mode	Operation mode
OFF	Winding	$\times 0.1$	Used	Used		Initialization	Advanced function	Tuning

※ Set the eighth (operation mode) DIP switches to "RUN" when you drive.

Teaching procedure

(This step is required only at the time of initial startup, and is not required during normal operation.)

- Set the minimum diameter (ϕ 80) by turning the pulser dial. Set the reel bobbin of the minimum diameter. Press the reel diameter reset key.

● Minimum diameter display

F.800 μ m

800 ϕ

● Maximum diameter display

0.800 μ m

300 ϕ

- Select the maximum reel diameter using the PALAM key, set the maximum diameter (ϕ 300) by turning the pulser dial. Set the reel bobbin of the maximum diameter. Press the reel diameter reset key.

- Set the operation mode of the DIP switch to "run", and turn on the power again.

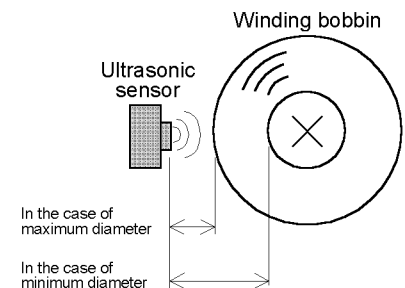

Manual operation (This step is required only at the initial startup, and is not required during normal operation.)

- Press the manual control mode key, and set the output ON/OFF switch to ON.
- Check diversified functions such as the motor and the sequence.

Automatic operation

- Press the automatic control mode key (only when the manual mode is selected).
- Adjust the tension to an appropriate value by turning the tension set trimmer.

1 Manual torque adjustment and the role of the pulser dial

Power switch 1 is set to ON. → Power indicator lamp is lit. Manual control mode key 17 is pressed. → Manual operation mode indicator lamp is lit.

Output ON/OFF key 13 is pressed. → Output indicator lamp is lit. Display selector key 8 is pressed. → Unit indicator lamp “ % ” is lit.

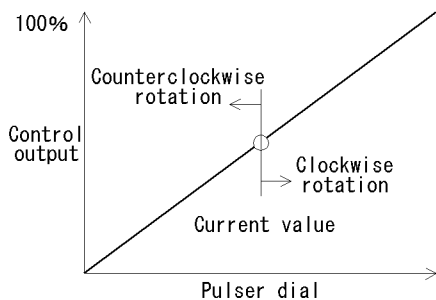

When the manual control mode is selected, the manual control output value just before becomes valid and is displayed on the monitor display 11. When the pulser dial 16 is turned clockwise or counterclockwise in this status, the control output is increased or decreased. After the control mode is changed over from manual to automatic, the output is gradually shifted to the output in accordance with the winding diameter.

All other diversified set data is saved in the memory inside the tension control unit.

When this data is read and displayed, then adjusted (increased or decreased) using the pulser dial, the adjusted result is saved as the latest data.

2 Relationship between the tension setting and the maximum tension

Power switch 1 is set to ON. → Power indicator lamp is lit. Automatic control mode key 14 is pressed. → Automatic operation mode indicator lamp is lit.

Output ON/OFF key 13 is pressed. → Output indicator lamp is lit. (PALAM key 8 is pressed. → Set value is displayed on display 4 in lower left.)

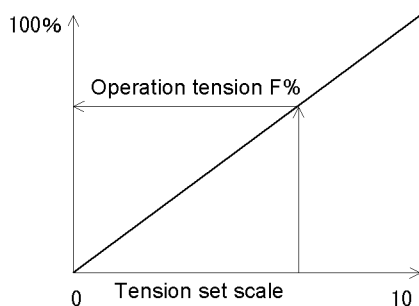

The set tension is changed within the range of 0 to 100% in accordance with the setting of the scales 0 to 10 of the tension set trimmer 15.

When the scale of the tension set trimmer 15 is required to be read correctly, press the PALAM key 8. Then, the set value is displayed as 0 to 100% on the display in lower left on the panel.

The 100% tension indicates the rated torque of the actuator divided by the maximum radius of the reel bobbin.

However, if a speed reducer is provided between the reel bobbin and the actuator, the 100% tension shall be the rated torque converted for the reel shaft.

The maximum radius shall be the maximum reel diameter set by the parameter divided by 2.

3 Role of the keyin inhibit key

Tuning mode

- While the DIP switch is set to select the tuning mode, all the parameters can be adjusted without regard to the setting status of the keyin inhibit function. However, parameters to which the keyin inhibit function is set in the adjustment mode cannot be displayed or set when the DIP switch is switched over to the operation mode.
- For example, if the keyin inhibit function is set to all the parameters in the tuning mode, the material thickness setting, the reel diameter setting and the tension setting exclusively are valid in the operation mode. (The system parameters can be set in the tuning mode exclusively without regard to the setting status of the keyin inhibit function.)
- Parameters to which the keyin inhibit function can be set
Taper ratio, stop timer, stop gain, stop bias, deceleration gain and acceleration gain

Operation mode

- When the keyin inhibit function is set in the operation mode, items for which change of the setting was valid become invalid with regard to change of the setting, and do not accept manipulation of the pulser dial. Such items do not accept the menu selection key either in the easy mode. (Manual control is valid.)
- The reel diameter reset key is valid without regard to the setting status of the keyin inhibit function. It is actuated when it is pressed and held for 1 sec or more.
In the advanced function mode, however, menu selection is not accepted while the machine is operating.

4. How to use the menu selection function

When eight types of menus are preliminarily registered by combining diversified parameters, the operator can perform optimal operation using diversified operation constants only by selecting a registered menu.

The following parameters can be registered for these menus.

- In the easy mode : Material thickness and initial diameter
- In the advanced function mode : Material thickness, initial diameter, taper ratio, stop timer, stop gain, stop bias, deceleration gain and acceleration gain

Setting ——— change by the menu selection even if displayed at the operation mode.

5 Flickering of indicator lamps and its meaning

- When the material thickness set key is pressed and the material thickness can be set using the pulser dial, the unit indicator lamp μ m flickers. It is lit when the initial diameter set key is pressed and the initial diameter unit lamp ϕ flickers when the PALAM key is pressed.
- When the initial diameter set key is pressed and the initial diameter can be set using the pulser dial, the unit indicator lamp ϕ flickers. It is lit when the material thickness set key is pressed and the material thickness unit lamp μ m flickers when the PALAM key is pressed.
- When the material thickness set key, the initial diameter set key or the PALAM key is pressed in the manual control mode, the manual operation mode indicator lamp flickers. At this time, the manual output is fixed to a value just before, and parameters can be set based on each set key using the pulse dial. When the manual control key is pressed again, the manual operation mode indicator lamp is lit and the manual output can be adjusted using the pulser dial.
- In the automatic control mode, the automatic operation indicator lamp is lit. In the advanced function mode, however, the automatic operation indicator lamp is lit while the RUN input is ON or flickers while the RUN input is OFF. While the stop timer is operating, the automatic operation indicator lamp is temporarily extinguished.
- Immediately after the power is turned on, the version flickers.
- When the calculated reel diameter is 2,000 mm or more, ϕ 2000 flickers as the reel diameter. When the calculated reel diameter is less than 0 mm, "-0.0.0." flickers as the reel diameter.
- While the control output is OFF, " OFF " flickers. While the weak excitation output is generated, a value flickers on the monitor display.

6 Taper ratio setting and output characteristics

Turn off the power, and set the DIP switch to select the advanced function mode. Turn on the power, then set the taper ratio.

Automatic control mode key 14 is pressed → Automatic operation mode indicator lamp is lit.

Output ON/OFF key 13 is pressed → Output indicator lamp is lit. Tension is set using tension set trimmer 15. → F% on previous page

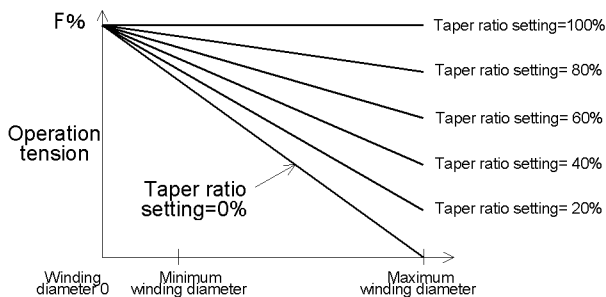

When the taper ratio is set to 100%, the constant tension operation is performed.

As the taper ratio is decreased, the tension at the maximum reel diameter is also decreased in accordance with the taper ratio.

Note that an ideal control shown in the figure on the left is not performed because the relationship between the control output and the actuator torque is nonlinear when a clutch brake is used as an actuator.

7 Non-linearity compensation function

- The nonlinear torque characteristics for the impressed voltage of powder clutch and brake as well as hysteresis clutch and brake is compensated.
- The compensation numbers for the powder clutch and brake as well as hysteresis clutch and brake, which are used in accordance with the table shown in Page 24, are set.
- The control output after compensation is made after nonlinear compensation for the signal which is in proportion of the reel diameter. (The control output is not in proportion of the reel diameter any more.)
- In the manual control mode, nonlinear compensation function is not operated.

8 Guideline of allowable minimum tension

The allowable minimum tension with which operation is possible in the torque tension control unit can be obtained using the following simplified formula.

$$F_{min} / (W+0.2) \geq 0.85 \alpha$$

- F_{min} : Minimum operation tension (kgf)
- W : Fully wound reel bobbin weight (ton)
- α : Acceleration/deceleration (m/min/s)

The graph on the left represents this formula.

If the machine is operated with a tension less than the minimum tension, stable operation cannot be assured when the machine is accelerated or decelerated.

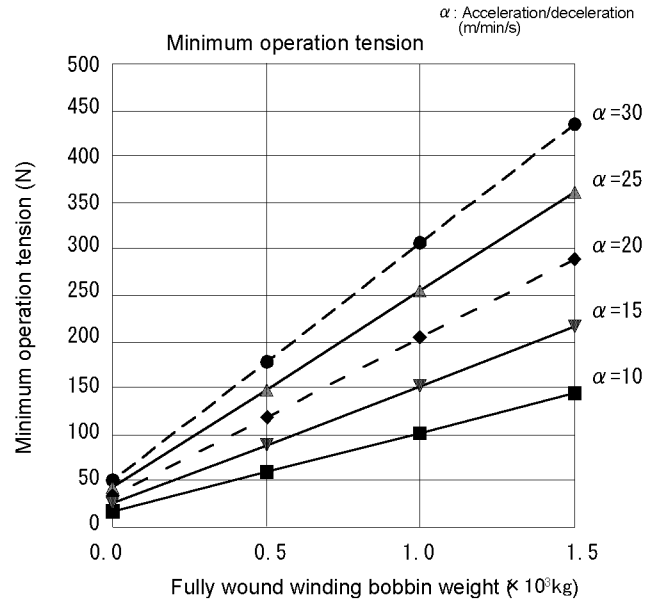

9 Major differences from the type LD-FB type tension control unit

The table below shows major differences between the conventional type LD-FB tension control unit and the type LD-30FTA tension control unit. The type LD-30FTA can be used as a succeeding model of the type LD-FB tension control unit

	Type LD-FB tension control unit	Type LD-30FTA tension control unit
Power supply	100/110 VAC dedicated, uninsulated output	100 to 240 VAC system, insulated output
Output capacity	DC24V 3.6A	DC24V 3.0A
Winding diameter calculation method	Integrated thickness method based on reel shaft pulse (1rotation = 1 pulse) Initial diameter and material thickness are set by digital switches on panel.	Integrated thickness method based on reel shaft pulse (1rotation = 1, 2, 4 or 8 pulses) When an optional card is mounted, reel diameter can be entered.
Inertia compensation control	Acceleration gain and deceleration gain are set by externally installed trimmer.	Acceleration gain, deceleration gain, stop gain, stop bias and stop timer are set by parameters.
Other functions	_____	Little excitation output, mechanical loss correction and tape ratio are set. Material thickness unit is changed over.

10 Output remote input and the output ON/OFF key provided on the panel

When this input is turned on/off, the remote function of control output is turned on/off. This input has the priority over the OUTPUT ON/OFF switch provided on the panel.

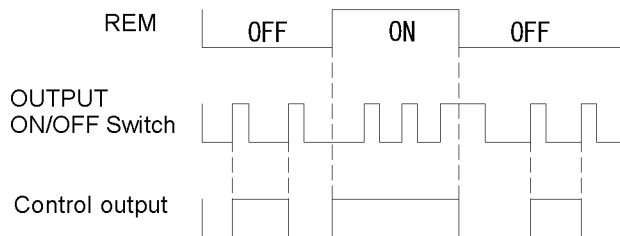

(Note) Use the Output ON/OFF key 13 or [REM] input without using the Power switch 1 when the output is turned on and off.
 • Allowable power switch cycles : 20,000 times

11 Relationship between the acceleration/deceleration gain and the winding/unwinding/backward rotation input

- The acceleration gain and the deceleration gain can be set respectively to 5 to 400% of the current output. To activate such gains, the ACC terminal (for the acceleration gain) and the DCC terminal (for the deceleration gain) are set to ON.
- In unwinding control, it is ideal to decrease the control output when the machine is started up and increase the control output when the machine is stopped.
In winding control, it is normal to increase the control output when the machine is started up and decrease the control output when the machine is stopped.
- Use any combination in accordance with your application without sticking to terms "acceleration" and "deceleration". When the operation direction is reversed and the backward rotation/forward rotation is given, arithmetic operation for pulses is automatically changed over between addition and subtraction.
However, as to the acceleration gain and the deceleration gain, change them over using an external sequence and set an appropriate control input ACC (or DCC) side to ON.

12 Supplement related to attachment of the winding diameter input

In the case of ultrasonic sensor

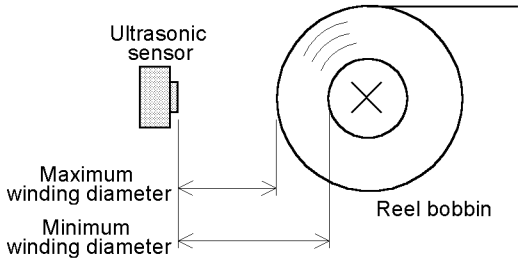

Install the ultrasonic sensor so that the distance detected by the ultrasonic sensor is in accordance with the sensor model, and becomes maximum when the reel diameter is minimum.

In the case of touch lever

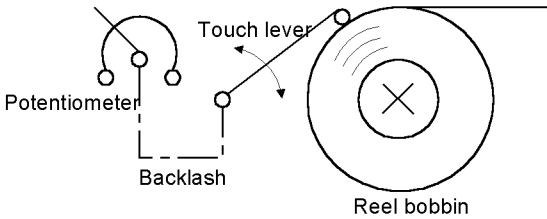

Install the touch lever so that the operation angle of the potentiometer becomes as large as possible. If the touch lever is vibrated caused by eccentricity of the reel bobbin, provide a backlash between the touch lever and the potentiometer drive shaft so that minute motions of the potentiometer are not repeated.

13 Non-linear compensation number table

Powder clutch			
Type name		No.	
Projection shaft type	Self-cooling	ZKG-5AN	101
		ZKG-10AN	102
		ZKG-20AN	103
		ZKG-50AN	104
		ZKG-100AN	105
		ZKB-0.06AN	81
		ZKB-0.3AN	82
		ZKB-0.6AN	83
	Self-cooling (Air-cooling)	ZKB-1.2BN	84
		ZKB-2.5BN	85
		ZKB-5BN	86
		ZKB-10BN	87
		ZKB-20BN	88
	Heat-pipe	ZKB-5HC	121
ZKB-10HC ※		122	
ZKB-20HC ※		123	
Water-cooling	ZKB-5CM ₂	111	
	ZKB-10CM ₂ ※	112	
	ZKB-20CM ₂ ※	113	
Explosion-proof Self-cooling	ZKB-40CM ₂ ※	114	
	ZKB-1.2B ₄ -909	131	
	ZKB-5B ₄ -909	132	
	ZKB-10B ₂ -909※	133	
Penetration shaft type	Self-cooling	ZKB-20B ₂ -909※	134
		ZA-0.6A	91
		ZA-1.2A ₁ /AN	92
		ZA-2.5A ₁ /AN	93
		ZA-5A ₁ /AN	94
		ZA-10A ₁ /AN	95
		ZA-20A ₁	96
	Self-cooling	ZKA-1A ₁	141
		ZKA-2A ₁	142
		ZKA-6A ₂	143
		ZKA-10A ₂	144
		ZKA-20A ₃	145
		ZKA-45AT ※	146
		ZKA-65AT ※	147
ZKA-100A ※	148		

Hysteresis clutch		
Type name		No.
Projection shaft type	ZHA-0.6B	151
	ZHA-1.2A	152
	ZHA-2.5A	153
	ZHA-5A	154
Penetration shaft type	ZHA-10A	155
	ZHA-20A	156
	ZHA-40A	157
	ZHA-60A	158

Powder brake			
Type name		No.	
Projection shaft type	Self-cooling	ZKG-5YN	51
		ZKG-10YN	52
		ZKG-20YN	53
		ZKG-50YN	54
		ZKB-0.06YN	1
		ZKB-0.3YN	2
		ZKB-0.6YN	3
		ZKB-1.2XN	4
	Self-cooling (Air-cooling)	ZKB-2.5XN	5
		ZKB-5XN	6
		ZKB-10XN	7
		ZKB-20XN	8
		ZKB-40XN ※	9
	Sermo-block	ZKB-2.5HBN	21
ZKB-5HBN		22	
ZKB-10HBN		23	
ZKB-20HBN		24	
ZKB-40HBN ※		25	
Water-cooling	ZKB-2.5WN	41	
	ZKB-5WN	42	
	ZKB-10WN	43	
	ZKB-20WN	44	
	ZKB-40WN ※	45	
Penetration shaft type	Self-cooling	ZA-0.6Y	11
		ZA-1.2Y ₁	12
		ZA-2.5Y ₁	13
		ZA-5Y ₁	14
		ZA-10Y ₁	15
		ZA-20Y ₁	16
	Water-cooling	ZA-40Y	17
		ZKA-2W	61
		ZKA-6W	62
		ZKA-10W	63
ZKA-20W	64		
ZKA-45W	65		

Hysteresis brake		
Type name		No.
Projection shaft type	ZHY-0.6B	71
	ZHY-1.2A	72
	ZHY-2.5A	73
	ZHY-5A	74
Penetration shaft type	ZHY-10A	75
	ZHY-20A	76
	ZHY-40A	77
	ZHY-60A	78
	ZHY-100A ₂	79

As the rated current of the models indicated by * mark will exceed the rated output current (3A) of LD-30FTA, please connect the power amplifier satisfying the rated current of each model to the TOUT-AOC terminal, then control through this power amplifier.